



LIFT KING

MOBILE 4-COLUMN PARKING LIFT

Model: Pro King 10XLT



Installation & Operation Manual

Jan. 2023

Index

1. Safety Cautions.....	3
1.1 Important statements	
1.2 Instructions for qualification of operators and users	
1.3 Cautions	
1.4 Safety signs	
1.5 Noise standard	
1.6 Training	
2. Introduction to Product.....	5
2.1 Product description	
2.2 Technical parameters	
2.3 Main structure part	
3. Installation Instructions.....	10
3.1 Preparation before installation	
3.2 Cautions for installation	
3.3 Installation procedures	
3.4 Last check	
4. Operation Instructions.....	15
4.1 Cautions for operation	
4.2 Operation flow chart	
4.3 Operating procedures	
5. Faults and Solutions.....	17
6. Maintenance Instructions.....	18
7. Attachments.....	19
Attachment 1– Packing List of Entire Machine	
Attachment 2– Winding Pattern of Wire Rope	
Attachment 3– Hydraulic Schematic Diagram	
Attachment 4– Exploded View of Machine	

Safety Cautions

1.1 Important statements

Please do note the tonnage mark on the machine. Do not try to lift any load that exceeds the rated lifting capacity.

Please read this manual carefully before installation and use of the lift, to avoid any property loss or personal injury caused by faulty operation.

No one is allowed to modify the control part and other mechanical parts of the machine without the manufacturer's permission.

1.2 Instructions for qualification of operators and users

1.2.1 Only personnel who have received professional training are allowed to operate and use the lift.

1.2.2 Electrical connection must be performed by qualified electricians.

1.2.3 Nonprofessionals shall not approach the lifting area.

1.3 Cautions

1.3.1 Do not install the lift on asphalt or tar ground. Concrete thickness must meet requirement.

1.3.2 Please read and understand Safety Cautions carefully before operation of the lift.

1.3.3 The lift shall not be used outdoor if not being customized to special requirements.

1.3.4 Hands and feet shall be away from moving parts of the lift. Move hands and feet away when the machine is descending, to avoid being crushed.

1.3.5 Only personnel who have received professional training are allowed to operate and use the lift.

1.3.6 Operators are not allowed to wear fat and loose clothes, to avoid being clamped by any moving part when the machine is descending or rising.

1.3.7 Ground around the lift must be kept clean and tidy, with no stacking of materials, in order to avoid accident.

1.3.8 The lift is designed to lift the entire car, not part of it. Do not try to lift any car beyond the rated lifting capacity.

1.3.9 Do make sure the safety lock of the lift is locked when personnel are working undercar.

1.3.10 Lifting block of the lift must be put at a place suggested by the car manufacturer, and then the car shall be lifted slowly. Check the car is stable without any risk of tipping, overturn or falling, before lifting it to the desired height.

1.3.11 Check whether any part is broken and check synchronicity of the machine and flexibility of moving parts at any time. Perform regular maintenance. Once any anomaly is detected, stop use immediately and contact your dealer.

1.3.12 Please lower the machine to the lowest position and turn off power after operation.

1.3.13 It is not allowed to modify any part of the lift without the manufacturer's permission.

1.3.14 If the machine is to stand idle for a long period of time, the user shall

- a. Turn off power;
- b. Drain off hydraulic oil;
- c. Lubricate moving parts with hydraulic oil.

Note: Do not drain liquid at random, in order to protect environment.

1.4 Safety signs



1.5 Noise standard

The lift makes noises less than 75dB. For your health, it is suggested to provide a noise meter in your operating area.

1.6 Training

Only personnel who have received professional training are allowed to operate and use the lift. We take pleasure in helping you if the manufacturer's professional training is needed.

Introduction of Product

2.1 Product description

This lift is a mobile parking lift. Its main parts include columns, tracks, movable brackets, hydraulic cylinder and motor pump unit.

When the motor pump unit is powered, gear pump starts to work. Hydraulic oil pushes cylinder rod up, pulling steel cable and hence raising tracks. During lifting, safety rack engages with safety lock automatically to make sure that no falling is caused by possible faults of the hydraulic system.

Safety structure chart:

Locked status:

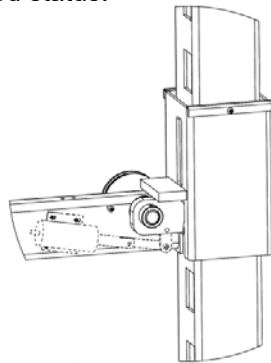

Fig. 1

Unlocked status:

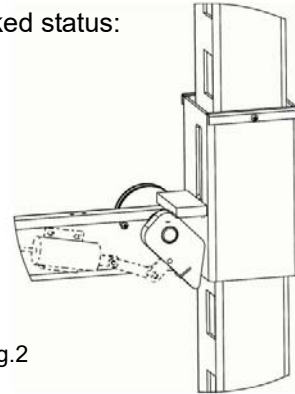

Fig.2

2.2 Technical parameters

2.2.2 PRO KING 9XLT

Model	Rated lifting capacity	Lifting time	Lifting range	Power supply
Pro King 10XLT	10000 lbs	50 Sec	5"---89.7"	240V, 50Hz, 15Amp. single phase

Maximum Lifting Clearance: 82"

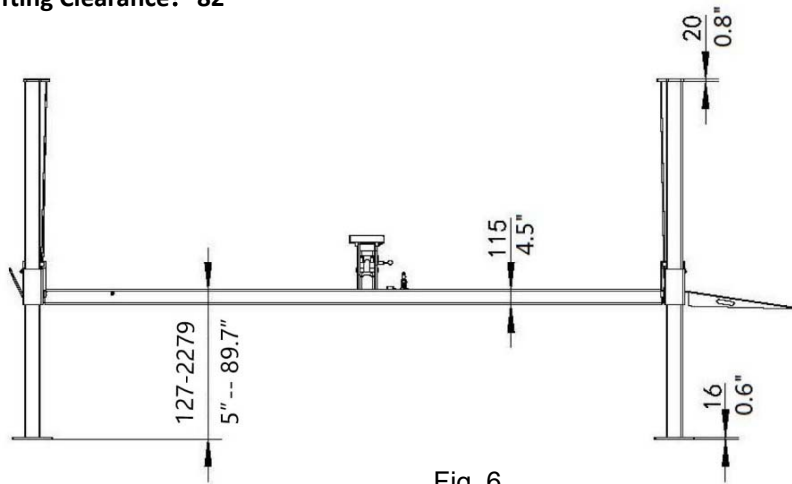

Fig. 6

Pro King 10XLT
Jan. 2023

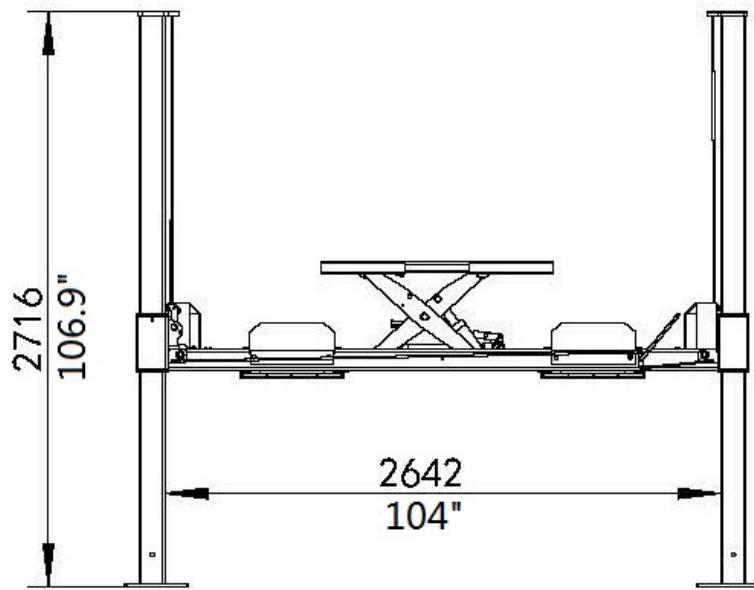

Fig. 7

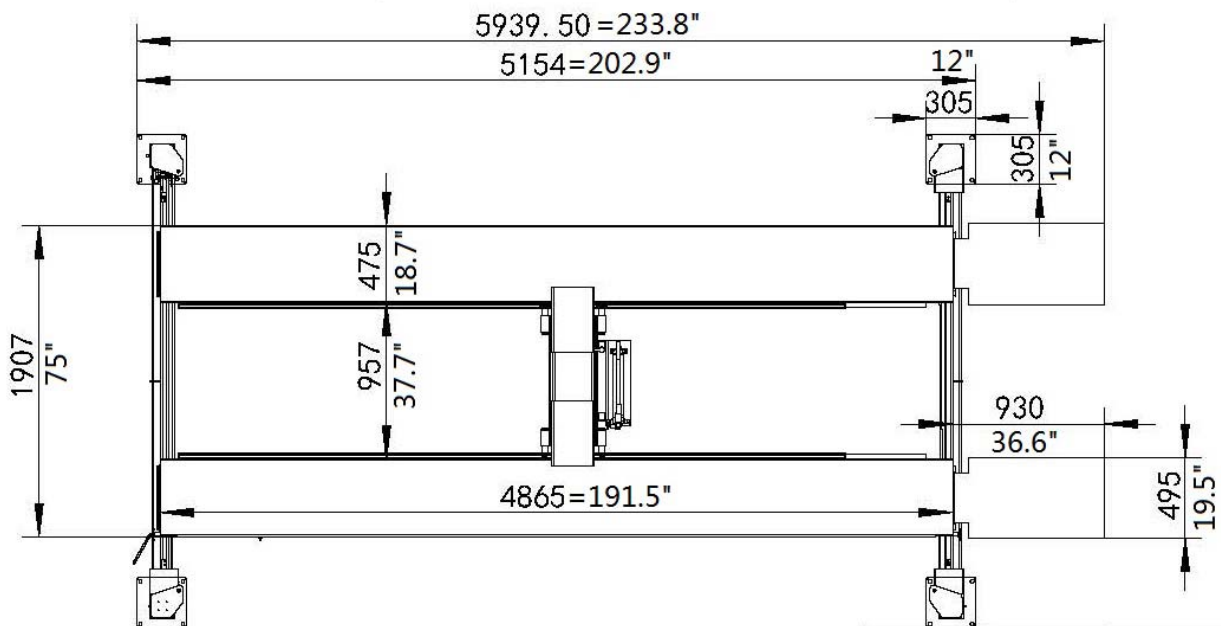

Fig. 8

2.3 Main structure chart

- 1: Control case mounting bar
- 3: Power unit / Motor pump
- 4: Main platform
- 5: Wheel rack
- 6: Offside platform
- 7: Column and cap
- 8: Cross beam
- 9: Approach ramp

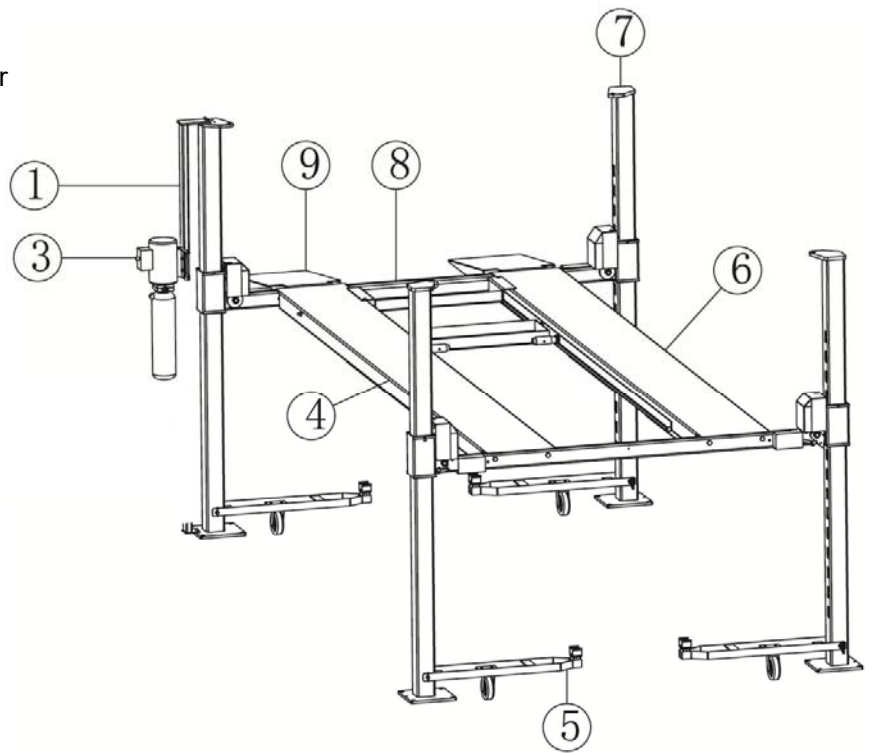

Fig. 9

Installation Instructions

3.1 Preparation before installation

3.1.1 Installation tools and lifting equipment

- Two open-end wrenches (17-19),
- 20 inch adjustable wrenches
- One 5mm screwdriver
- 12L of 46# anti-wear hydraulic oil
- One 1 ton capacity lifting equipment
- One measuring tape, one chalk

3.1.2 Check against Packing List – Attachment 1 (Packing List of Entire Machine)

Unpack the package and check whether the parts are complete against Attachment 1 (Packing List of Entire Machine). Contact your dealer or the manufacturer immediately once any omission is detected. The dealer will not take any responsibility for and solve any problem for free, if any missing part is detected but the machine is still installed with the missing part unresolved.

3.1.3 Requirements for ground

This lift must be installed on flat and solid concrete ground, with the concrete strength being above 3000psi and the thickness being 200mm or greater, Within whole area the flatness error being less than 5mm. Newly poured concrete shall be cured for more than 20 days in dry condition without direct exposure to sunshine.

3.2 Cautions for installation

- 3.2.1 Conduits and electric wires must be connected correctly, to avoid oil leakage and loosening of wires.
- 3.2.2 All the bolts must be tightened.
- 3.2.3 No car shall be put on the machine during trial run.

3.3 Installation procedures

Step 1: selection of a proper installation site

This lift shall be installed indoor. It shall be installed on solid concrete ground, not on any expansion joint of cement ground. It must not be installed on the second or higher floor, without permission of relevant building personnel.

Step 2: determination of layout

When installation site is selected, mark positions of four columns with a measuring tape and a chalk and make sure two diagonal lines equal each other. See the following drawing (Fig.10)

The space from column to wall must be kept as more than 800mm for safe walking.

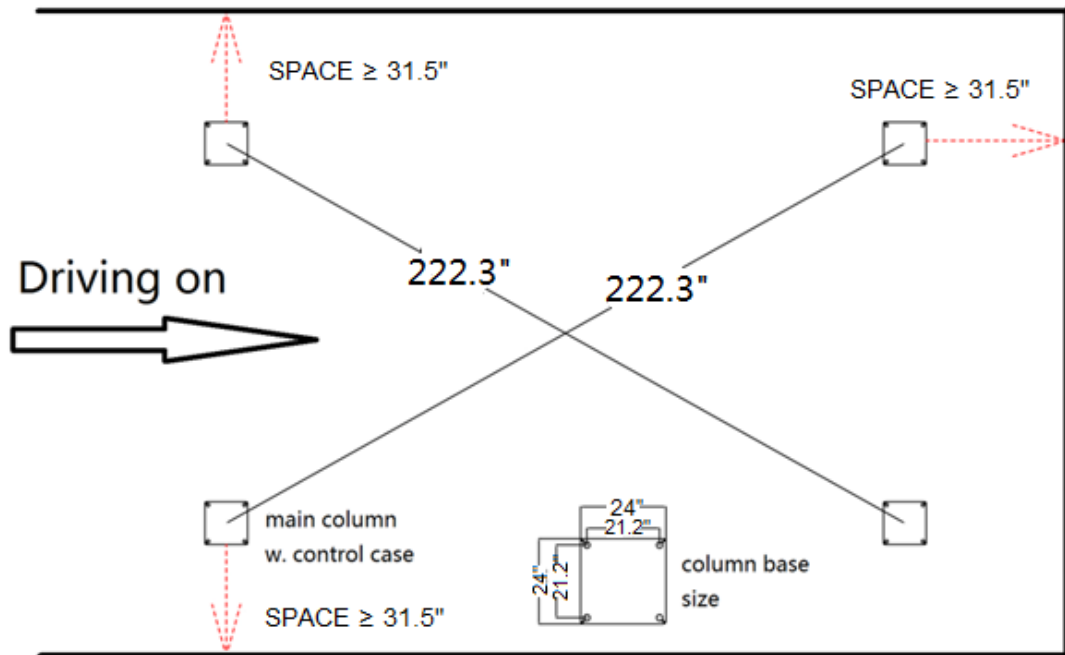

Fig. 10

Step 3: Unloading and unpacking

Step 4: Set up of columns (Fig. 11)

After unpacking, set up the four columns as Fig. 11

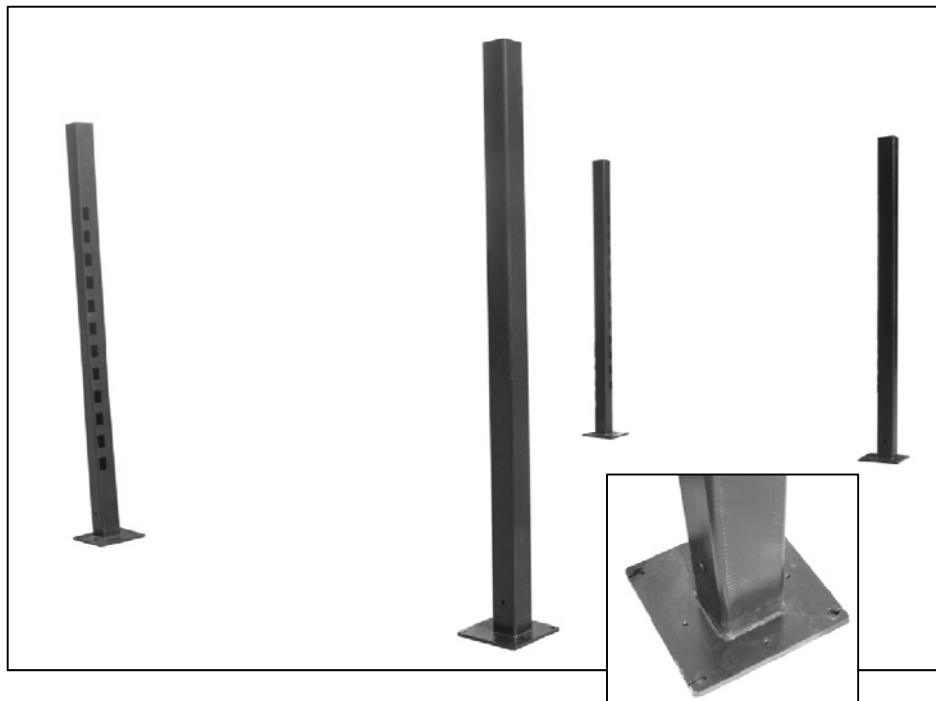

Fig. 11 (Main column with holes on base plate)

Step 5: Installation of cross beams (Fig. 12 - 24)

1. Take away the cover plate from the collar by turn off the screw.(Fig.12)
 2. Using a piece of cardboard to stop the lock.(Fig. 13)
 3. Install the crossbeam.(Fig.14)
 4. Take away the cardboard and let the crossbeam rest on 4th position.(Fig.15)
 5. Put in the nylon sliders and mount on the cover plate.(Fig. 16-17)
- (The slider with cut must be at the column cutting corner as in the picture)



Fig.12



Fig. 13



Fig. 14



Fig. 15

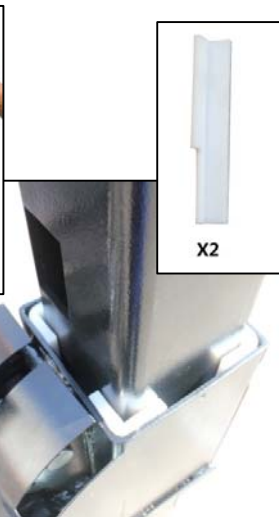

Fig. 16

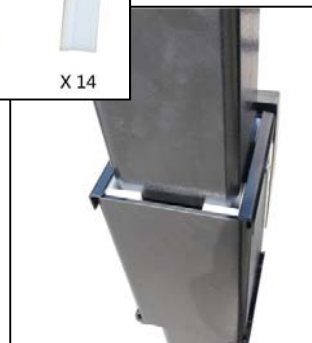
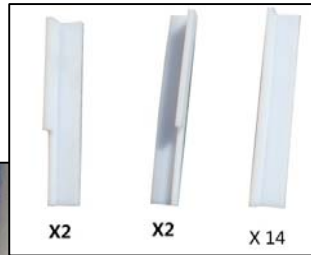

Fig. 17

Step 6: Mounting on platforms (Fig. 18-19)

Put the platforms on the crossbeams. Bolt them together by bolts and nuts.

The platform with cylinder must be near the main column and the roller rails must be in the middle.



Fig. 18



Fig. 19

Step 7: installation of steel cable (Fig. 20)

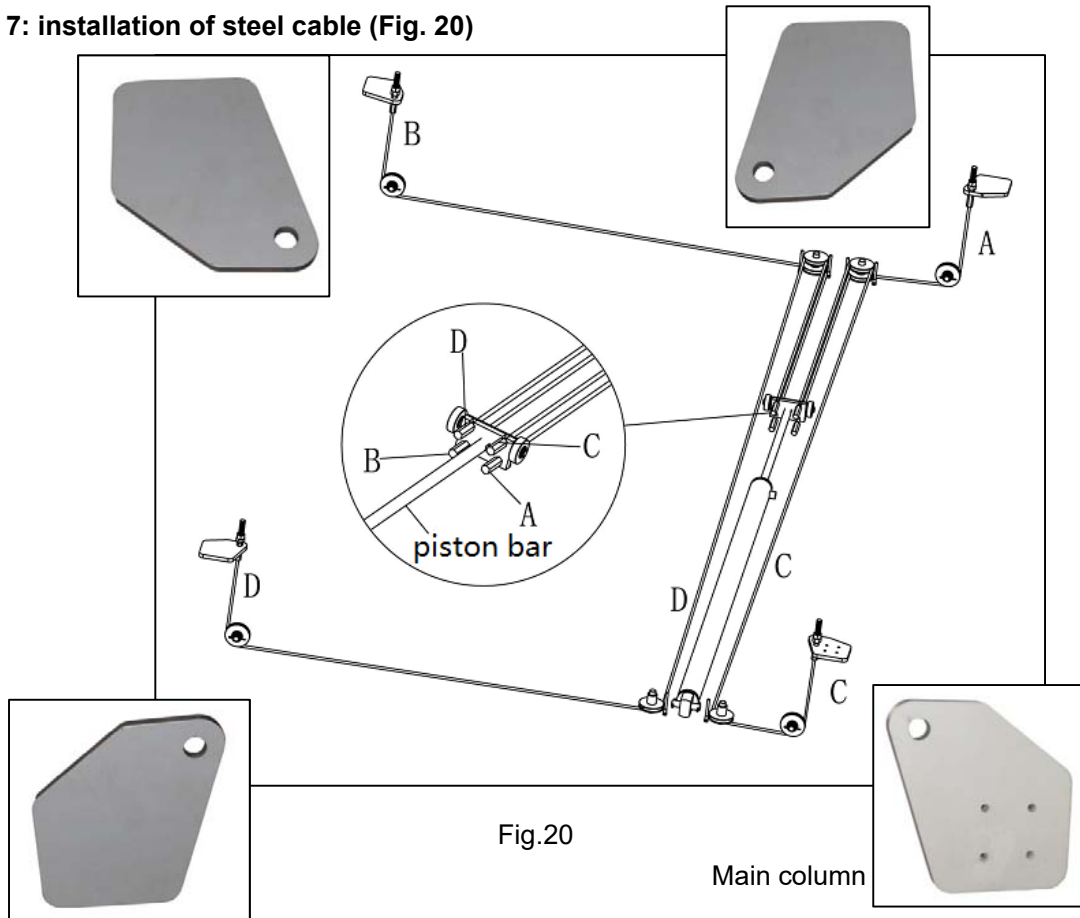

Fig.20

Main column

1. Put on the column top caps as Fig. 18. The one for main column is with holes (Fig.21).
2. Pull the cylinder to make sure that the cables are long enough.
3. Put on the cable-cut safe roller on the latch (Fig. 22a)
4. Get the cables out from the end of the platforms then round the rollers and be fixed on the column top (Fig. 22b).



Fig. 21



Fig. 22a



Fig. 22b

Step 8: installation of safety lock-release device

Mount on the items on the crossbeam as Fig. 23 -- Fig. 25



Fig. 23



Fig.24a



Fig. 24b

Step 9: Motor pump mounting & connecting

Fix the control case mounting bar on the main column by bolts and screws. (Fig. 26). It can be on the side or in the front.

Then mount the motor pump on the bar by bolts and nuts also.

Fill about 12L of HM46# anti-wear hydraulic oil into the oil tank.

Connect the hydraulic hose from motor pump to cylinder under main platform through a fitting. (Fig.27-28)



Fig.26



Fig. 27

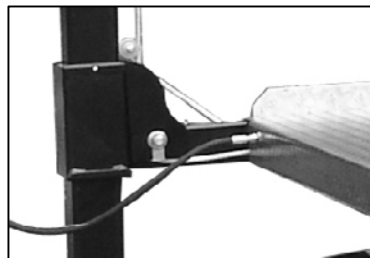

Fig. 28

Step 10: Power hooking:

Power supply : 240V, 50Hz, single phase, 15A.

Make the Electrical hookup to the motor pump (240V, Single Phase). It is recommended that a 240 Volt, 15Amp twist lock plug be installed in the power line just ahead of the power control case.

Size wire for 20 amp circuit.

Warning: the wiring must comply with local code. Have a certified electrician make the electrical hook-up to the power control case and motor pump. Protect each circuit with time delay fuse or circuit breaker 240V single Phase, 60 Hz 15 Amp. Motor cannot run on 60hz without a physical change to motor.

Step 11: steel rope tension adjusting

Note: the four locks must be at same height while doing this.

After the four safety locks totally rest on the same height, (if not, loose the steel rope nut on the column top), turn the nut on the column top to shorten the rope on each column so that the tension of the ropes are almost same. Please keep the lock still rest on the rack (It is about to leave the rack but not).

Step 12: trial running (the machine must be unloaded)

Turn on the power switch on the power supply box on the wall then press the UP lifting button until the steel ropes are tensioned. Then release the button. It is very important to check whether all of 4 steel ropes stay within the rope groove at this moment.

Then press the UP button again until the machine rises to the highest position. It will be stopped by the cylinder extension limit.

While rising, the locks will knock the columns making 'Clang-Clang' noise. It is normal that the sound may not synchronous. It depends on the leveling of the ground and the tension on each rope.

Press down the DOWN lever. The locks will rest on the racks of the columns and the platforms will stop at the height.

Again press the UP button to rise the platforms a little. Then hold down the lock-release lever to release all the locks. At the same time, press down the DOWN lever. The lift will lower down by gravity until the DOWN button is released. In the lowering, pay attention to the locks, until the machine descends to the lowest position.

Note: If any lock does not released before going down, the platforms will not be leveling.

Try to adjust the length of the steel cable to make all locks released before platforms moving down.

Up and down the lift from ground to top for several times to get air out from the cylinder and hose.

3.4 Last check

- a. There must be no oil leakage in the hydraulic system including motor pump, valves, hose, cylinder and all connections.
- b. Steel cable nuts must be tightened and locked on the column top.
- c. All electric wiring / connection are perfect.
- d. The platforms are leveling. (Note: this is depended on the floor and cable adjusting)

Operation Instructions

4.1 Cautions for operation

- 4.1.1 All the conduit connections shall be checked. Operation may not be performed unless it is confirmed that there is no oil leakage.
- 4.1.2 Operation is not allowed where safety device is faulty.
- 4.1.3 Check whether the center of gravity of the car to be lifted is at the center of the lifting platform. If not, please adjust the center of gravity before lifting.
- 4.1.4 In the lifting/lowering process, operators and all the other relevant personnel shall stand within safe areas.
- 4.1.5 When the platform is raised to the desired height, operators shall turn off power when leaving the control box, to avoid faulty operation by other personnel.
- 4.1.6. Make sure the safety lock of the lift is locked before personnel operate under car. Make sure nobody is under the car before lifting/lowering operation.

4.2 Operation flow chart

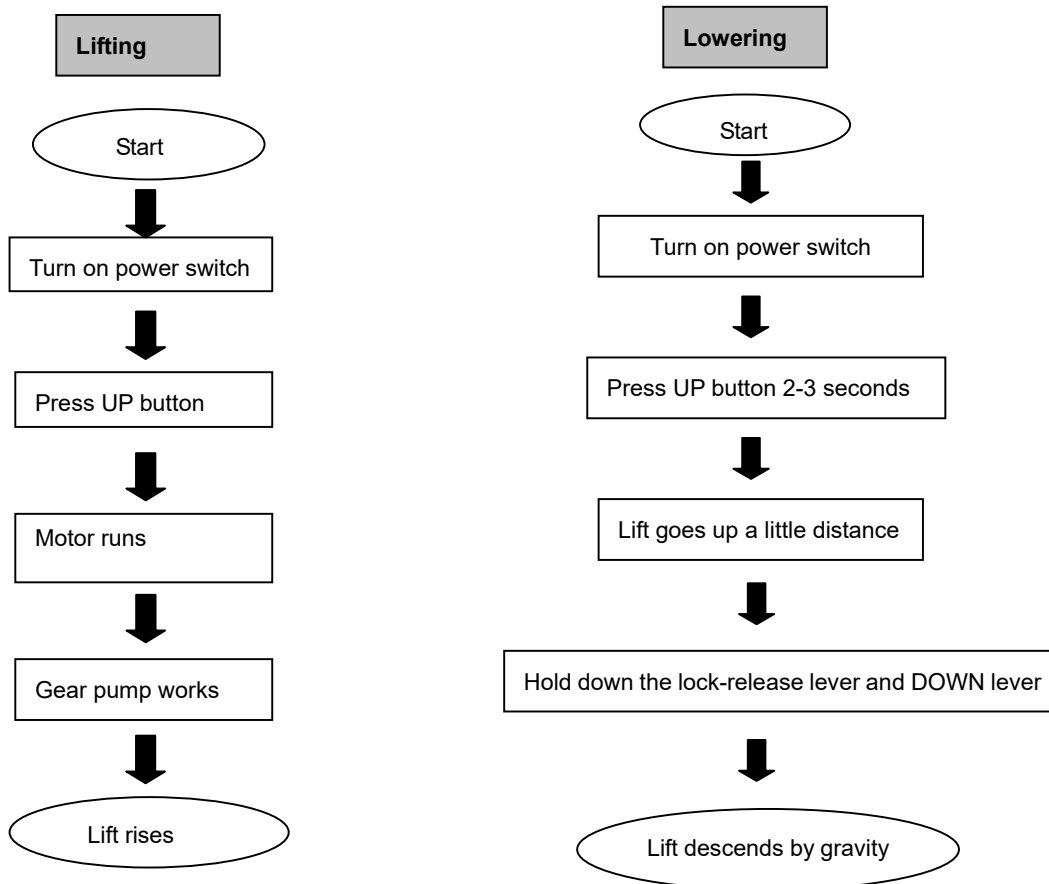

4.3 Operating procedures

WARNING: Read and understand the operation instructions before operating this machine

Raising a vehicle:

1. Drive a car through the ramp on the platforms. Then stop it in the middle of the platform. Pull parking brake (It is better put some wood to block the wheel).
2. Press the UP button to raise the car a small distance above the ground. Then check the status of the car again.
4. Lift the car to the desired height. Press DOWN lever to rest the platforms on the safety locks.

Lowering the lift:

1. Press UP button 2-3 seconds to rise the platforms a little height.
2. Hold down the lock-release lever and the DOWN lever to lower the platforms.
2. Drive the car off after the lift descends to ground.

Moving the lift:

Note: only lift itself allow to be moved by the wheels. No load is permitted on the lift while moving.

1. Empty the lift by driving away the vehicle.
2. Lift up the platforms to two feet high.
3. Mount on the wheel racks.(Fig. 29)
4. Lower down the platforms till the cross beams rest on the wheel racks and the column leaving the ground.
5. Push the columns to move the lift to new position.
6. Rise up the platforms again.
7. Take away the wheel racks.
8. Lower down the platforms to ground.

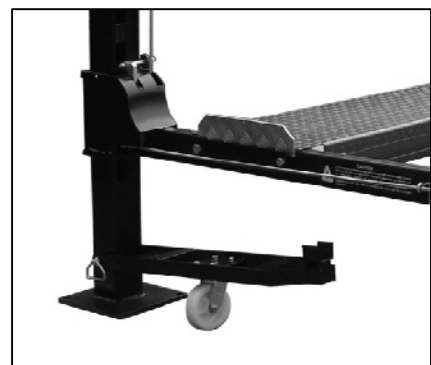

Fig. 29

Faults and Solutions

Note: If you could not troubleshoot any fault, please ask the manufacturer for help. We will help you solve the problem as soon as possible. Provision of relevant information and photos of the fault allows the manufacturer to solve the problem faster.

Fault	Reason	Solution
Motor does not run and lift does not work.	Electric wire connection is poor.	Check and connect wires correctly.
	Motor is burned.	Replace the motor.
Motor rotates but lift does not work.	Motor reverses.	Correct electric wire connection.
	Overflow valve is loose or blocked.	Adjust or clean overflow valve.
	Gear pump needs priming or it is broken.	Prime or Replace gear pump.
	Hydraulic oil is insufficient.	Add hydraulic oil.
	Oil suction pipe is loose or drops.	Tighten oil suction pipe.
	Buffer valve is loose or blocked.	Tighten or clean buffer valve.
Slow lowering down occurs after lifting.	Check if there is oil leakage at any conduit.	Replace conduit.
	Cylinder is sealed poorly.	Replace seals.
	One-way valve is sealed poorly.	Disassemble, clean, resolve, or replace
	Overflow valve works poorly.	Disassemble, clean, resolve, or replace
	Manual unloading valve works poorly.	Disassemble, clean, resolve, or replace
Slow lifting	Filter clogs up.	Clean, resolve, or replace
	Oil is mixed with air.	Add hydraulic oil.
	Overflow valve is not well adjusted.	Adjust correctly.
	Hydraulic oil turns hot (above 45°).	Stop to cool down or replace hydraulic oil.
	Seals of cylinder are worn out.	Replace seals or cylinder.
Slow lowering	Explosion-proof throttle valve for lowering is blocked by obstacle.	Replace, Clean, resolve or replace the explosion-proof throttle valve.,
	Hydraulic oil is not clean.	Replace hydraulic oil.
	There is obstacle in conduit.	Clean or replace conduit.

Maintenance Instructions

Simple routine maintenance at low cost can ensure normal operation and safety of the machine. The frequency of routine maintenance may be determined on the basis of the frequency suggested as below and according to operating environment and times of the lift.

6.1 Items to be checked before operation every day

Operators must perform inspection before operating the machine. It is very important to check safety lock, which must be checked every day. Inspection in advance prevents serious loss, waste of time and personal injury.

- . Check the locked status of the mechanical safety lock before and during operation.
- . Check connection and possible leakage of hydraulic hose and connection.
- . Check electric connection.
- . Check whether anchors are tight (if anchored).
- . Check connection of lifting / lowering brackets.

6.2 Items to be checked weekly

- . Check flexibility of moving parts.
- . Check conditions of safety parts.
- . Check volume of hydraulic oil by pressing the lifting button to raise the platform to the highest position. If it fails to reach that position, hydraulic oil in the oil tank is insufficient and shall be added.
- . Check whether anchors are tight (if anchored).

6.3 Items to be checked monthly

- . Check whether bolts are tight.
- . Check sealing of hydraulic system. If oil leakage is detected, tighten the joint.
- . Check lubrication and wear of parts that need lubrication. Once any damage is detected, replace the damaged part promptly.

6.4 Items to be checked yearly

- . Drain the oil tank off to check status of hydraulic oil.
- . Check lubrication and wear of parts that need lubrication. Once any damage is detected, replace the damaged part promptly.

Note: If the machine is maintained in strict accordance with the aforesaid requirements, the machine will be in normal working conditions all the time and most of accidents can be avoided.

Attachments

Attachment 1 - Packing List of Entire Machine

1	Parking lift	Component	1
2	Carton box of power unit	Standard part	1

Attachment 2 -Winding Pattern of Wire Rope

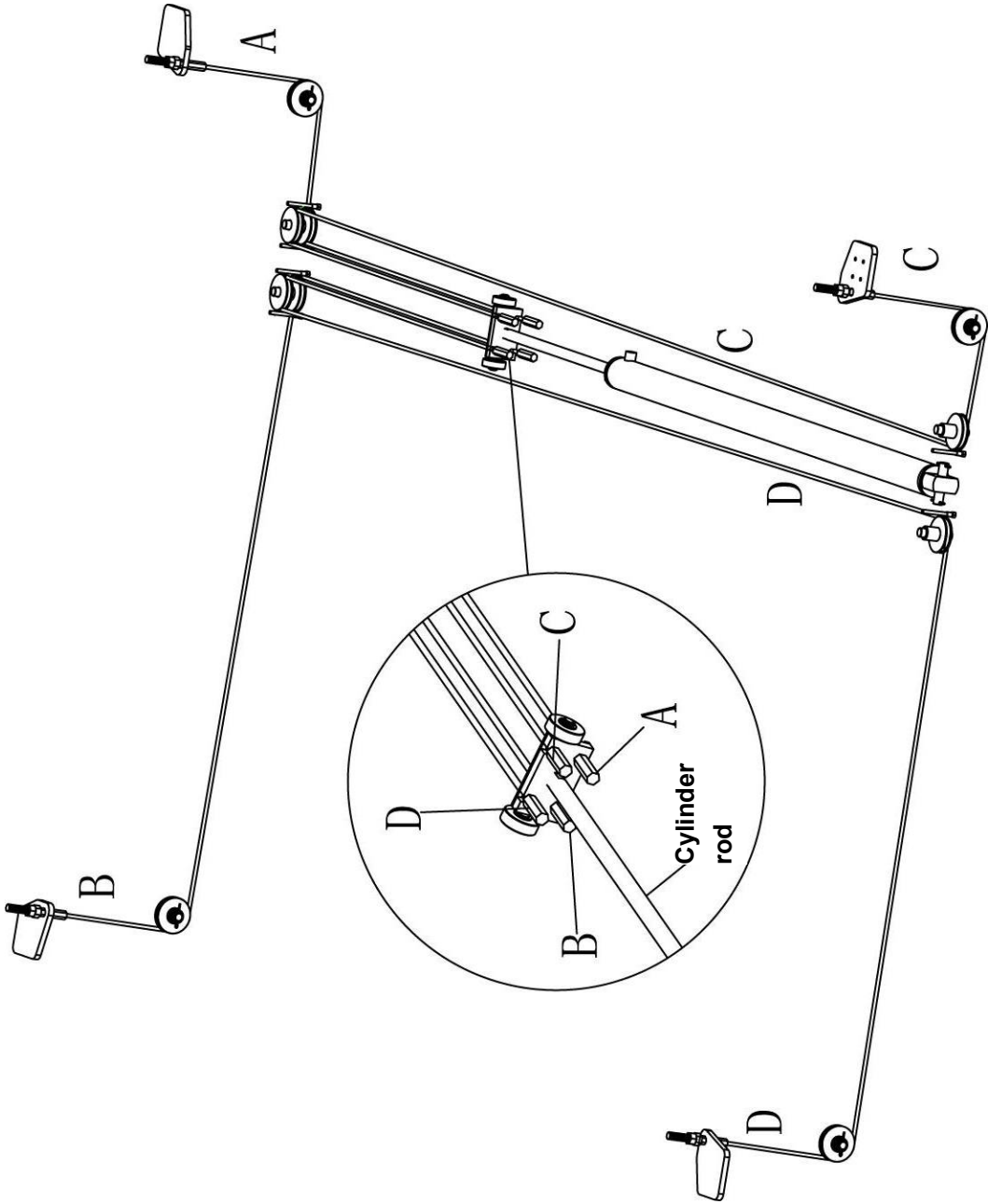

Attachment 3 - Hydraulic Schematic Diagram

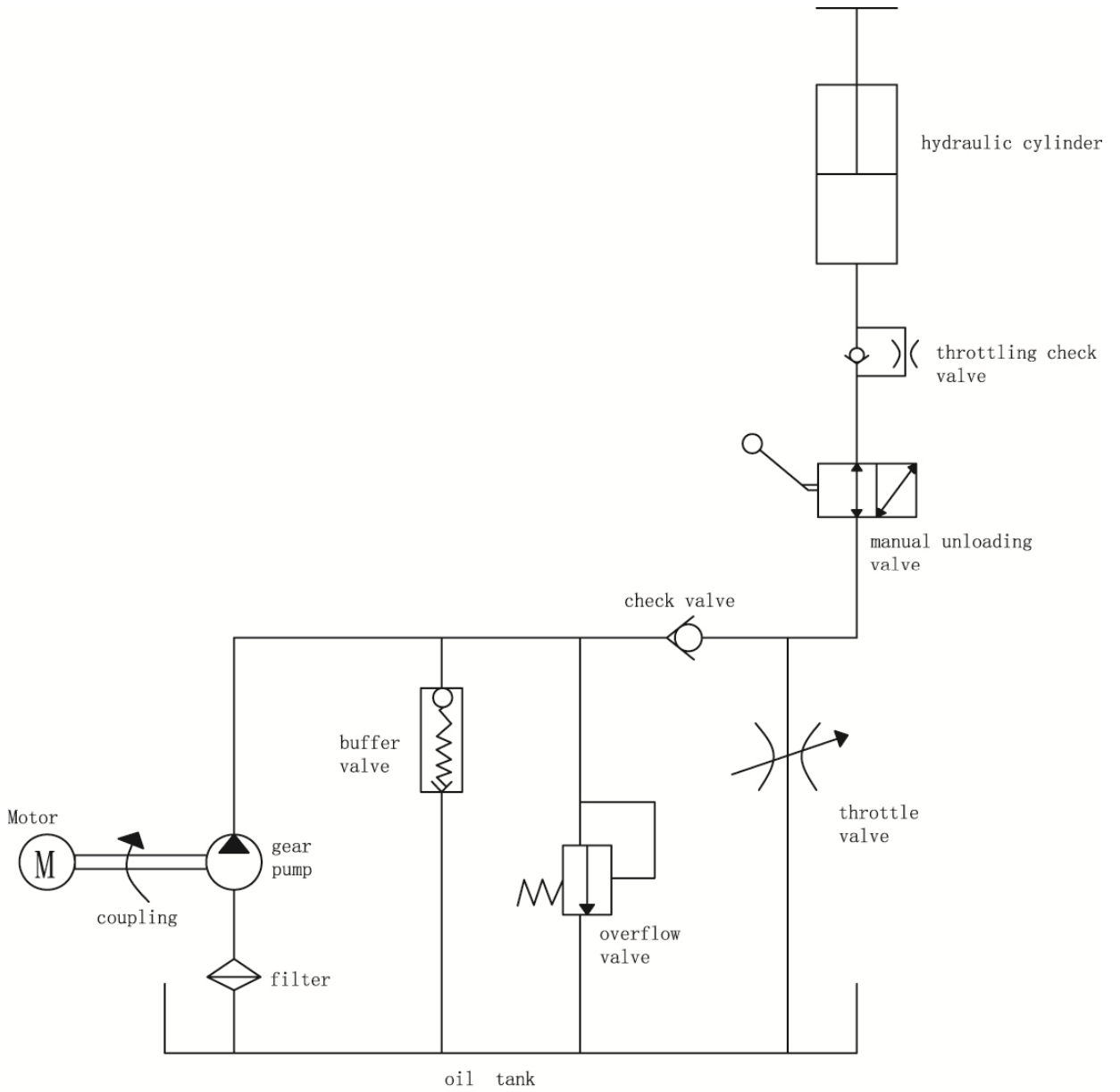

Attachment 4 Exploded View of Machine

Parts Drawing Fig.2

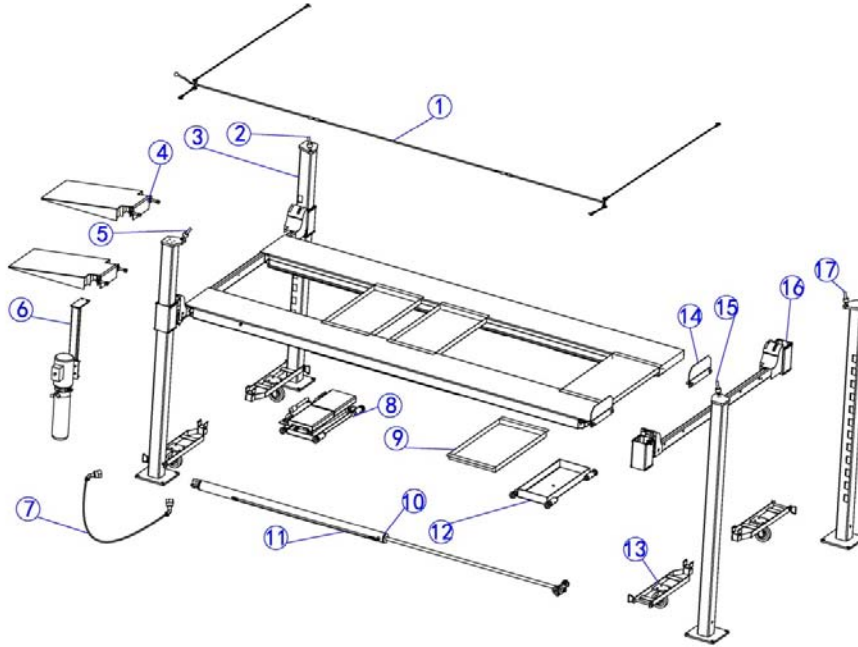

ITEM	Pro King 10XLT	DESCRIPTION	QTY	Note
2-1	SA4T40L-A5	lock-release set	1	
2-2	SA4T40L-A10	cable	1	9540mm(375.6")
2-3	SA4T40L-A1	column set	1	1 main, 3 sub
2-4	SA4T40L-A4	ramp set	2	
2-5	SA4T40L-A11	cable	1	8105mm(319.1")
2-6	SA4T40L-A6	power unit set	1	
2-7	SA4T40L-A9	oil pipe	1	2170MM(85.4")
2-8	MPJ25-00	rolling jack	1	(option)
2-9	SA4T40-A16	plastic jack tray	4	
2-10	SA4T40L-A3-B9	cylinder	1	
2-11	SA4T40-A8	oil pipe	1	1840mm(72.4")
2-12	SA4T40-A15	rolling tool box	4	
2-13	SA4T40L-A14	dolly kit	4	
2-14	SA4T40-A7	stopper	2	
2-15	SA4T40L-A13	cable	1	3390mm(133.5")
2-16	SA4T40L-A2	crossbeam	2	
2-17	SA4T40L-A12	cable	1	4830mm(190.2")

Pro King 10XLT

Jan. 2023

20

Parts Drawing Fig.3

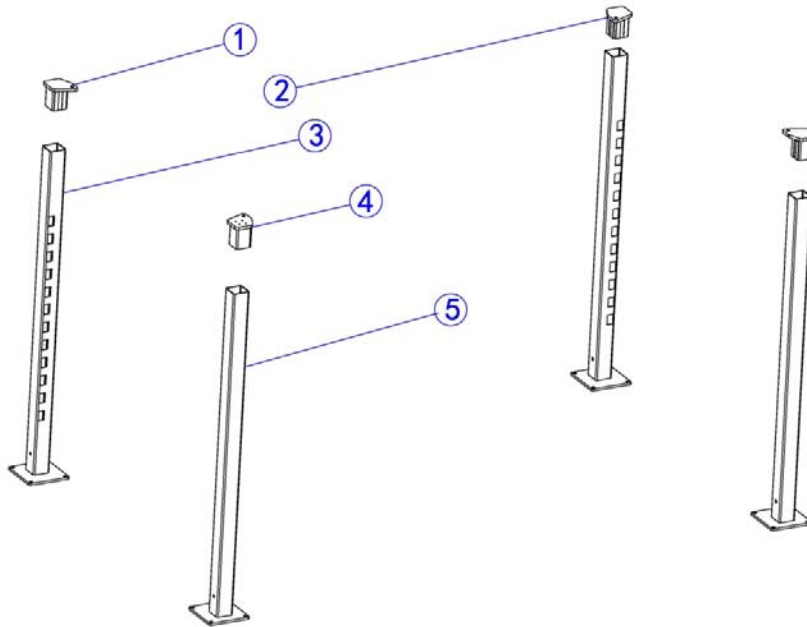

ITEM	Pro King 10XLT	DESCRIPTION	QTY	NOTE
3-1	SA4T40-A1-B4	top cover of sub column A	2	
3-2	SA4T40-A1-B5	top cover of sub column B	1	
3-3	SA4T40L-A1-B1	sub column	3	A*2+B*1
3-4	SA4T40-A1-B3	main top cover	1	
3-5	SA4T40L-A1-B2	main column	1	

Parts Drawing Fig.4

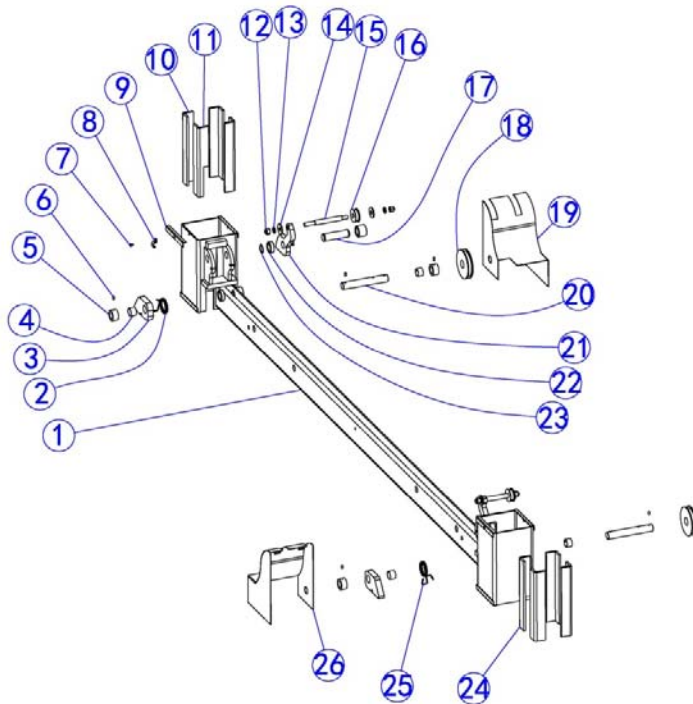

ITEM	Pro King 10XLT	DESCRIPTION	QTY	NOTE
4-1	SA4T40L-A2-B1	crossbeam	2	
4-2	SA4T40-A2-B18	torsion spring	2	left side
4-3	SA4T40-A2-B3	main safety lock	4	
4-4		bearings	1	2520
4-5	SA4T40-A2-B12	spacer bush	8	253820
4-6		Threaded pin	12	M6*12
4-7		Philips pan head screw	8	M6*8
4-8	SA4T40-A2-B14	pipe snap clamp	1	
4-9	SA4T40-A2-B11	slide block	8	
4-10	SA4T40-A2-B8	nylon slide	12	
4-11	SA4T40-A2-B9	nylon slide	2	w. left opening
4-12		self-locking nut	8	M12
4-13		lock washer	8	D12
4-14		flat washer	8	D12
4-15	SA4T40-A2-B2-C2	rolling rod	4	
4-16	SA4T40-A2-B2-C3	rolling wheel	4	
4-17	SA4T40-A2-B7	shaft	4	
4-18	SA4T40-A2-B19	pulley	4	

ITEM	Pro King 10XLT	DESCRIPTION	QTY	NOTE
4-19	SA4T40-A2-B16	beam cover	2	right side
4-20	SA4T40-A2-B5	beam shaft	4	
4-21	SA4T40-A2-B2-C1	broken rope lock	4	
4-22	SA4T40-A2-B6	spacer bush	4	
4-23		circlip	8	D25
4-24	SA4T40-A2-B10	nylon slide	2	w. right opening
4-25	SA4T40-A2-B17	torsion spring	2	right side
4-26	SA4T40-A2-B13	beam cover	2	left side

Parts Drawing Fig.5

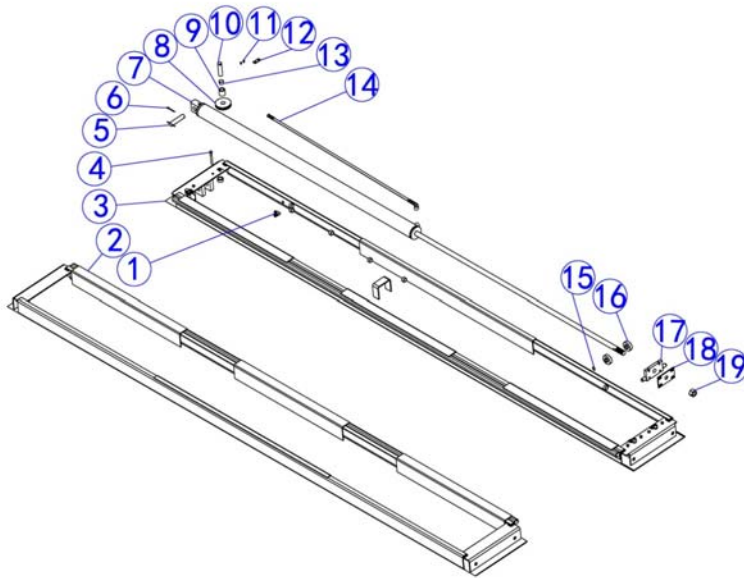

ITEM	Pro King 10XLT	DESCRIPTION	QTY	NOTE
5-1	SA4T40-A3-B3	connector	1	
5-2	SA4T40L-A3-B2	sub platform	1	
5-3	SA4T40L-A3-B1	main platform	1	
5-4	SA4T40-A3-B8	anti-skip shaft	6	
5-5	SA4T40-A3-B9-C4	cylinder shaft	1	
5-6		cotter	2	4*50
5-7	SA4T40L-A3-B9-C1	cylinder	1	
5-8	SA4T40-A2-B19	pulley	6	
5-9	SA4T40-A3-B4	spacer bush	4	
5-10	SA4T40-A3-B6	wheel shaft	4	
5-11		Philips pan head screw	8	M6*12
5-12	SA4T40-A3-B7	fixing plate for axle	4	
5-13		bearing	6	2518
5-14	SA4T40-A8	oil pipe	1	1840mm (72.4")
5-15		circlip	6	D20
5-16	SA4T40-A3-B9-C6	rolling wheel	2	
5-17	SA4T40-A3-B9-C2	large clamp block of wire rope	1	
5-18	SA4T40-A3-B9-C3	small clamp block of wire rope	1	
5-19		self-locking nut	1	M27

Parts Drawing Fig.6

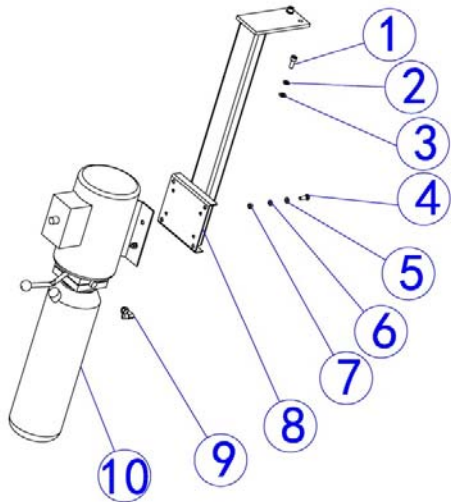

ITEM	Pro King 10XLT	DESCRIPTION	QTY	NOTE
6-1		Allen screw	2	M6*12
6-2		lock washer	2	D12
6-3		flat washer	2	D12
6-4		bolt	4	M8*25
6-5		lock washer D8	4	D8
6-6		flat washer D8	4	D8
6-7		nut	4	M8
6-8	SA4T40-A6-B1	motor mounting bar	1	
6-9	SA4T40-A6-B3	connector	1	
6-10	SA4T40L-A6-B2	motor pump	1	2.2Kw

Parts Drawing Fig.7

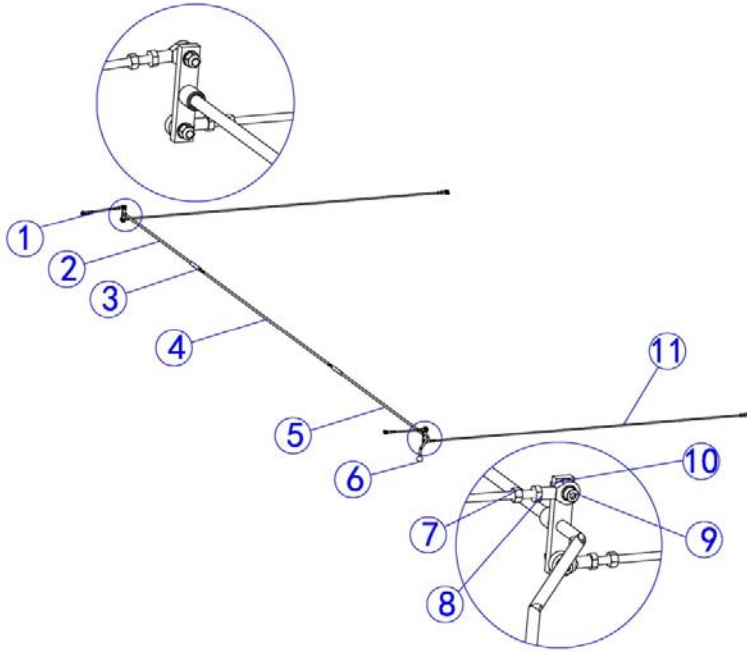

ITEM	Pro King 10XLT	DESCRIPTION	QTY	NOTE
7-1	SA4T0L-A5-B3-C1	short rod	2	
7-2	SA4T0L-A5-B1	T-linking rod	1	
7-3	SA4T0-A5-B1-C3	spacer sleeve	2	
7-4	SA4T0L-A5-B1-C4	long linking rod	1	
7-5	SA4T0L-A5-B1-C1	T-linking rod w. handle	1	
7-6	SA4T0-A5-B1-C6	handle ball	1	
7-7		nut	16	M8
7-8	SA4T0-A5-B2-C2	knuckle bearing	8	M8
7-9		Allen screw	20	M8*35
7-10		nut	4	M8
7-11	SA4T0L-A5-B2-C1	long rod	2	

Parts Drawing Fig.8

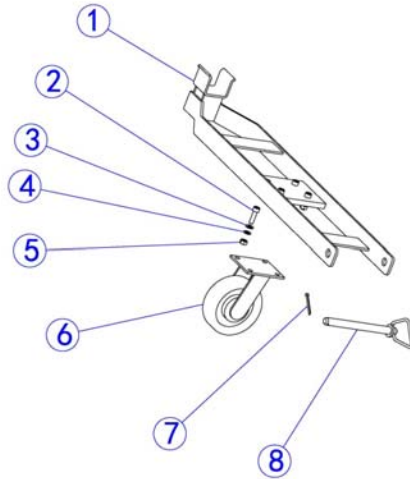

ITEM	Pro King 10XLT	DESCRIPTION	QTY	NOTE
8-1	SA4T0L-A14-B1	dolly kit frame	1	
8-2		Allen screw	4	M10*35
8-3		flat washer	4	D10
8-4		lock washer	4	D10
8-5		nut	4	M10
8-6	SA4T0-A14-B2	swivel wheel	1	6"
8-7		split pin	1	5*45
8-8	SA4T0-A14-B3	dolly pin	1	

Parts Drawing Fig.9

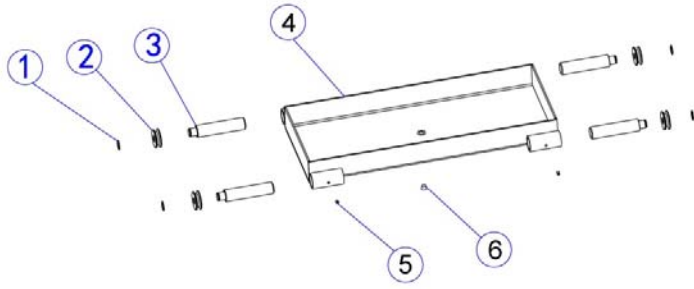

ITEM	Pro King10 XLT	DESCRIPTION	QTY	NOTE
9-1		circlip	4	D25
9-2	MPJ25-A1-B3	rolling wheel	4	
9-3	MPJ25-A1-B2	pin	4	
9-4		Tool case	1	
9-5		threaded pin	4	M6*8
9-6		end nut	1	NMPT 3/8"