



LIFT KING

AIR MOTORCYCLE LIFT

INSTRUCTIONS • PARTS DRAWING • PARTS LIST

Model PH1100

WARNING: READ INSTRUCTIONS BEFORE OPERATING

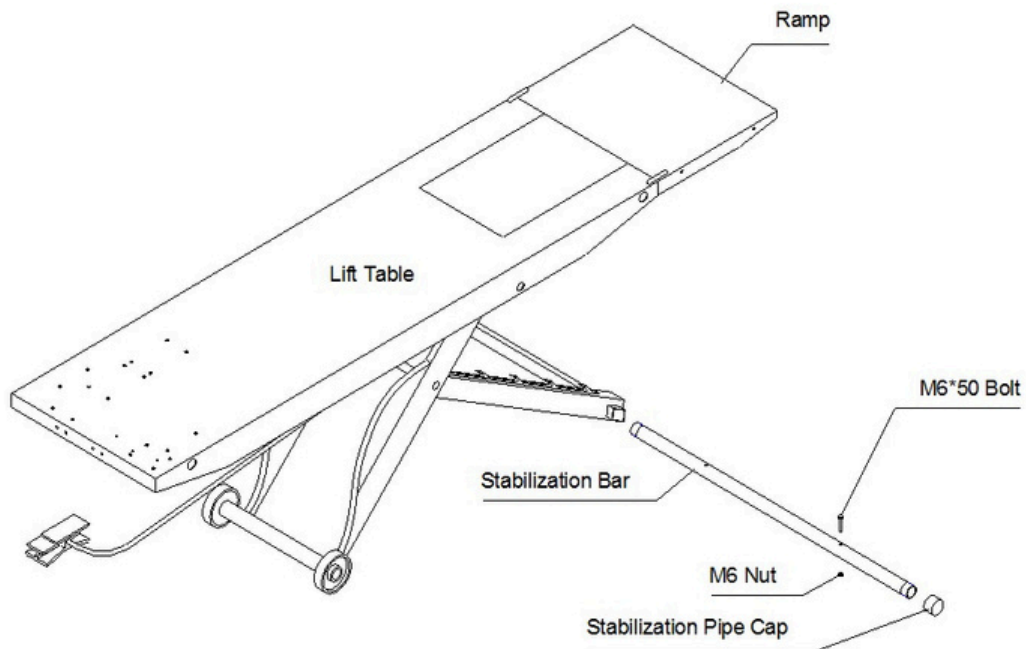

1. Center load on table – 455Kg maximum.
2. Connect to 0.7Mpa(7bar) maximum shop air.
3. Keep safety bar in position at all times – except when lowering.
4. Keep hands and tools from under carriage.
5. Do not mount table when in elevated position.
6. Do not ride vehicle onto lift.
7. Lift must be in the lowered position when moving.
8. Only trained persons should operate Air Motorcycle Lift.
9. The working area should be sufficiently lit.
10. Foot controller should be at least 0.9 meter away from Air Motorcycle Lift during raising and lowering operation.
11. Lift is recommended for indoor use only.

AIR MOTORCYCLE LIFT

NOTE: READ ENTIRE MANUAL TO COMPLY WITH ALL SAFETY AND SERVICE PRECAUTIONS. DEATH, PERSONAL INJURY AND/OR PROPERTY DAMAGE MAY OCCUR UNLESS INSTRUCTIONS ARE FOLLOWED CAREFULLY.





INSTRUCTIONS

UNPACKING AND SET-UP

Open carton, then remove ramp, and shipping boards.

-  Connect foot-operated air valve to 0.7Mpa air supply. The lift may be damaged and/or personal injury may result if the pressure exceeds the maximum 10.7 Mpa rating. Stand clear of lift table, and depress the UP side of foot valve to raise table. To lower table, lift detent bar from safety latch and lower to next position or to floor. Insert ramp mounting pins into holes at either end of table to mount ramp. NOTE: If cycle vise is being installed, ramp must be mounted opposite the cycle vise.

OPERATION

-  1. Loads must be centered on table at all times.
-  2. Loads must be firmly positioned and secured on table at all times.
- 3. All mobbing parts have been lubricated at the factory and should be re-lubricated every (6) months to prevent galling. Grease nipples are located at each and of frame pivot shaft and at top ends of inside frame assembly.
- 4. Lightly oil cylinder rod when it becomes dry.
- 5. Squirt some oil through air bleed hole in plate end of cylinder to lubricate piston and its seal every (6) months.
- 6. Pivot shaft set screws should be checked frequently to be sure they are tight. These are located at the top end of the inside frame assembly.

OTHER OPTIONS AVAILABLE

Separate installation instructions included with option.

DESCRIPTION
FRONT EXTENSION – Extends lift top to 2362mm for longer wheel base motorcycles
FRONT CYCLE VISE – Used to stabilize motorcycle while on lift
SIDE EXTENSION SET – Expands width of lift from 610 to 1220 mm includes stabilizer bar

AIR MOTORCYCLE LIFT

REPLACEMENT PARTS

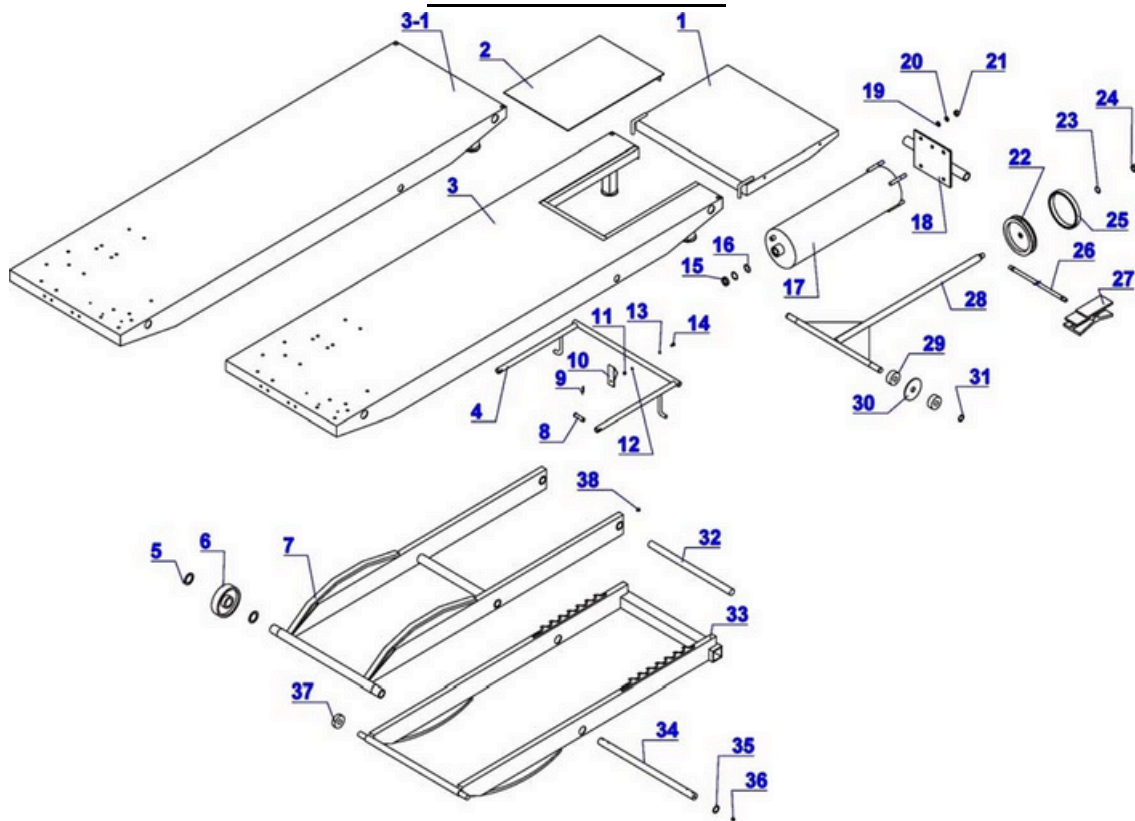

ITEM	DESCRIPTION	QTY
1	Ramp	1
2	Drop out cover	1
3	Top assembly	1
3-1	Top assembly	1
4	Detent bar	1
5	Retaining ring	4
6	Wheel	2
7	Scissor frame A	1
8	Clevis pin	2
9	Cotter pin	2
10	Detent clip	1
11	Nut	1
12	Washer	1
13	Lockwasher	1
14	Screw	1
15	Wiper ring	1
*16	O-ring	2
17	Cylinder	1
18	Cylinder end plate	1
19	Washer	4

ITEM	DESCRIPTION	QTY
20	Lockwasher	4
21	Nut	4
22	Piston	1
*23	O-ring	1
24	Nut	1
25	Piston seal	1
26	Valve hose w/fitting	1
27	Foot valve assembly	1
28	Cylinder shaft assembly	1
29	Cam roller bearing	4
30	Cam bearing space	2
31	Retain ring	2
32	Cylinder pivot shaft	1
33	Scissor frame B	1
34	Frame pivot shaft	1
35	Retaining ring	2
36	Oil cup	4
37	Track roller bearing	2
38	Screw	2

* Easily Worn Parts

3612P03 300mm SIDE EXTENSION Installation Instructions

MOUNTING INSTRUCTIONS

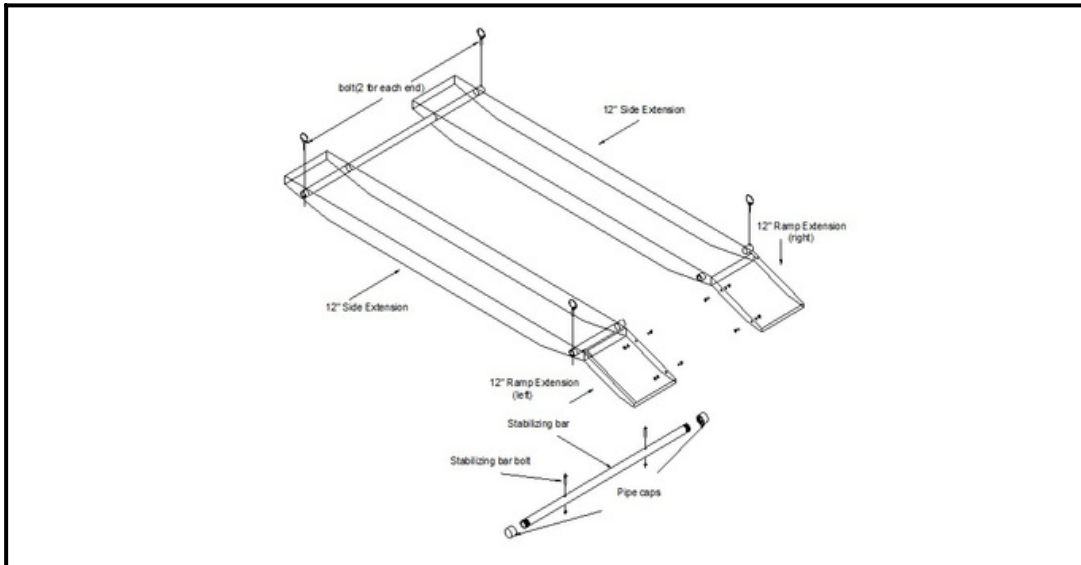

1. Insert pipes from extension panel package through holes in lift table.
2. Mount panels on ends of pipe on each side of table. With ramp hole to outside.
3. Insert M8 BOLT provided through holes in each end of pipe.
4. Secure ramp extensions to ramp with bolts provided. Make sure ramp hooks are positioned on the outside.
5. Stabilization bar directions – Unscrew cap from one of the ends of the stabilization pipe, Insert bolt in drilled out hole and tighten with nut. Slide pipe through the stationary square tubing on the lift legs. Insert the other bolt, tighten down with nut. Put on the other cap and tighten.

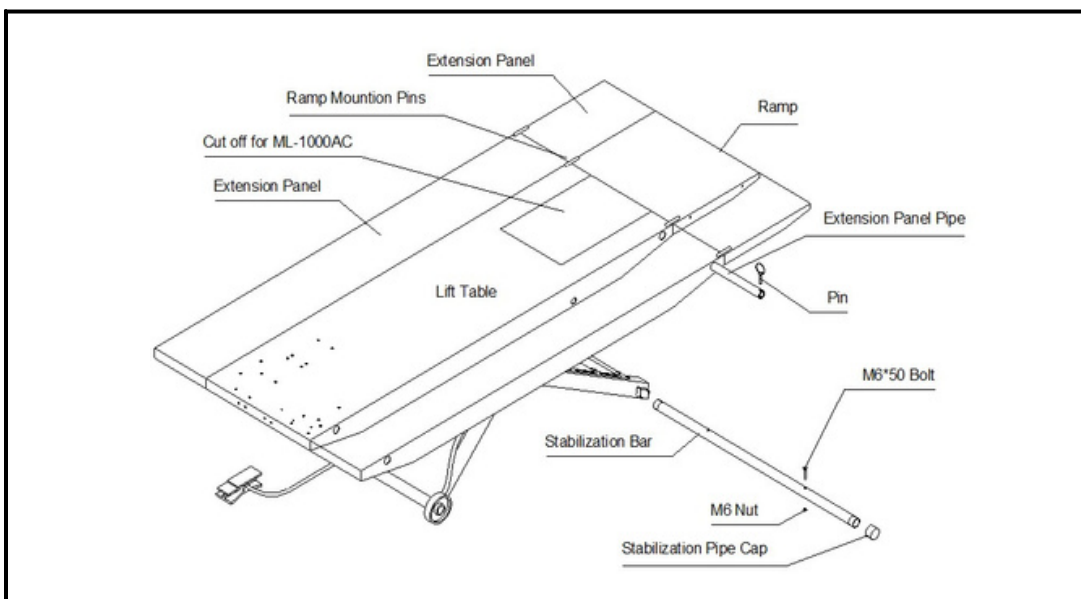

3612P01 330mm FRONT EXTENSION

Installation Instructions

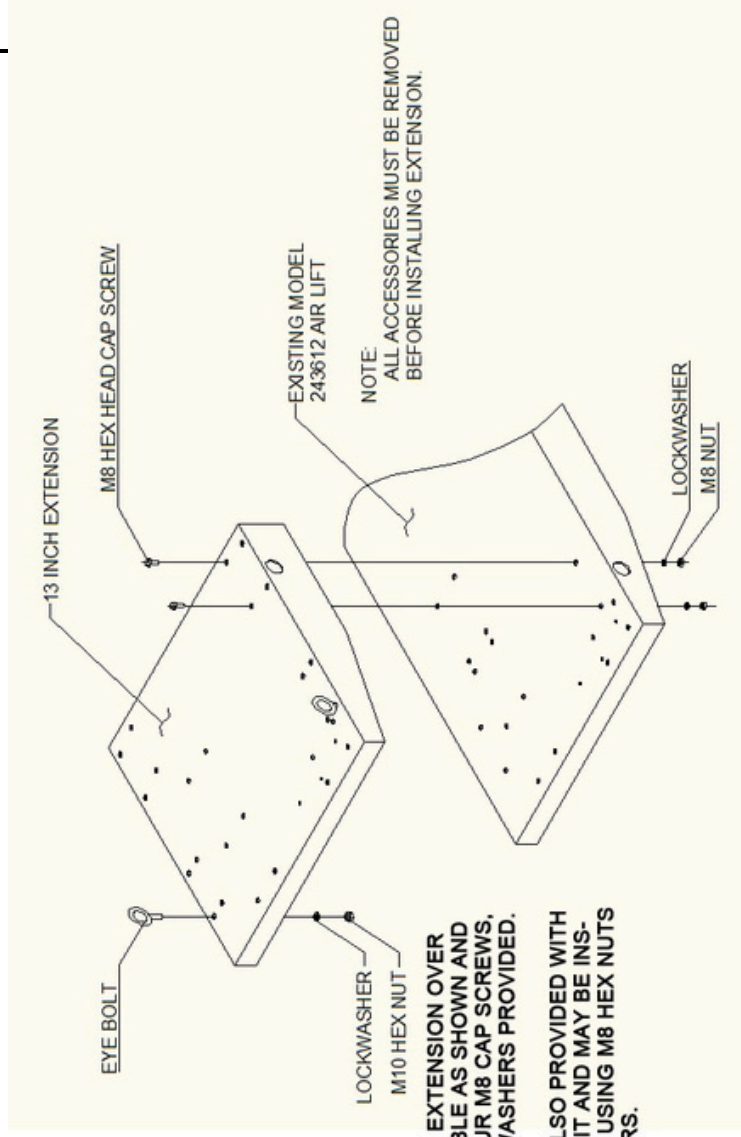

POSITION THE 13" EXTENSION OVER THE EXISTING TABLE AS SHOWN AND ATTACH WITH FOUR M8 CAP SCREWS, NUTS AND LOCKWASHERS PROVIDED.

EYE BOLTS ARE ALSO PROVIDED WITH THE EXTENSION KIT AND MAY BE INSTALLED AS SHOWN USING M8 HEX NUTS AND LOCKWASHERS.

3612P02 Cycle Vise

Installation Instructions

The 3612P02 Cycle vise mounts directly onto the Air Motorcycle Lift

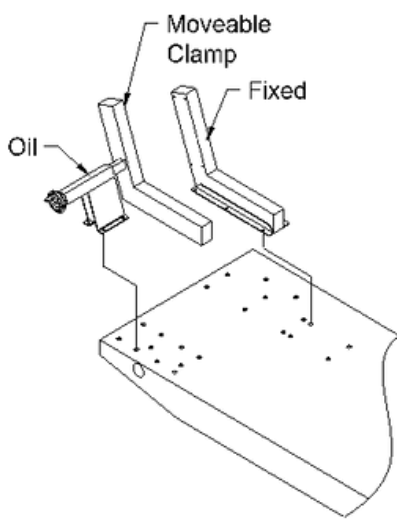

Align two inside hole of the fixed clamp over the existing vise hole pattern as show.

Align the moveable clamp with the locating corner hole.

